



CERTUSS

EFFICIENT
PRODUCTION
WITH STEAM

CERTUSS STEAM GENERATORS
MADE IN GERMANY

THE BEST STEAM

The best steam is produced as consistently quietly, easily, and reliably as possible with low energy and water consumption. Those who need industrial steam for their production processes benefit from these characteristics. And these are the performance features that have made CERTUSS steam generators a market leader in this industry.

CERTUSS reliability

The result of rigorous quality inspections of all components and production processes.





In more than 80 sectors, such as healthcare, the chemical, pharmaceutical and automotive industries, the hotel business, and the food and beverage sector, CERTUSS steam generators are an established name worldwide. With consistent research and advanced development along with the highest quality standards, for more than 60 years we have been developing gas-fired, oil-fired, and electric steam generators. The output classes for modules heated by fossil fuels range up to 2,000 kg/h and up to 320 kg/h per steam boiler for electric steam generators.

CERTUSS systems are known for a high degree of modularity. They can be combined into an intelligent multiple system in order to provide significantly larger outputs (up to 16 t/h).



One principle with many advantages:

the CERTUSS water tube boiler principle



Reinventing steam



How can you produce steam of the highest quality that is directly available with maximum reliability and without lengthy preheating times? The CERTUSS water tube boiler principle and an intelligent control system make it possible. Our team developed this technology consistently over decades. In connection with the typical CERTUSS design, we can supply compact, space-saving solutions that function quite economically. This means that in most countries, the installation conditions for these systems are more permissive.

Our systems only produce exactly the amount of steam that is needed right then in the production area. This makes them economical and environmentally sound. All CERTUSS steam generators meet the current ecological standards. We provide country-specific certifications and other acceptance protocols by request.



All CERTUSS heating coils are developed, manufactured, and inspected in the factory in Krefeld.

Common paths

building a strong global presence

With expertise and continuity



The acquisition of CERTUSS by the Japanese company Miura Co. Ltd. has created a strong, internationally positioned company. As part of the Miura family, the world's leading manufacturer of boiler room solutions, we secure our position in the international steam boiler market with expertise, innovative technologies and a strategic vision.

The strong CERTUSS brand will remain in place globally. The merger with Miura Co. Ltd. will give Certuss an even more global presence. Together, we operate internationally and are therefore closer to our customers. With our technologies, we help to save energy and thus make a sustainable contribution to protecting our environment. Security of supply and high customer satisfaction are our goals.



CERTUSS is part of the **MIURA** Group

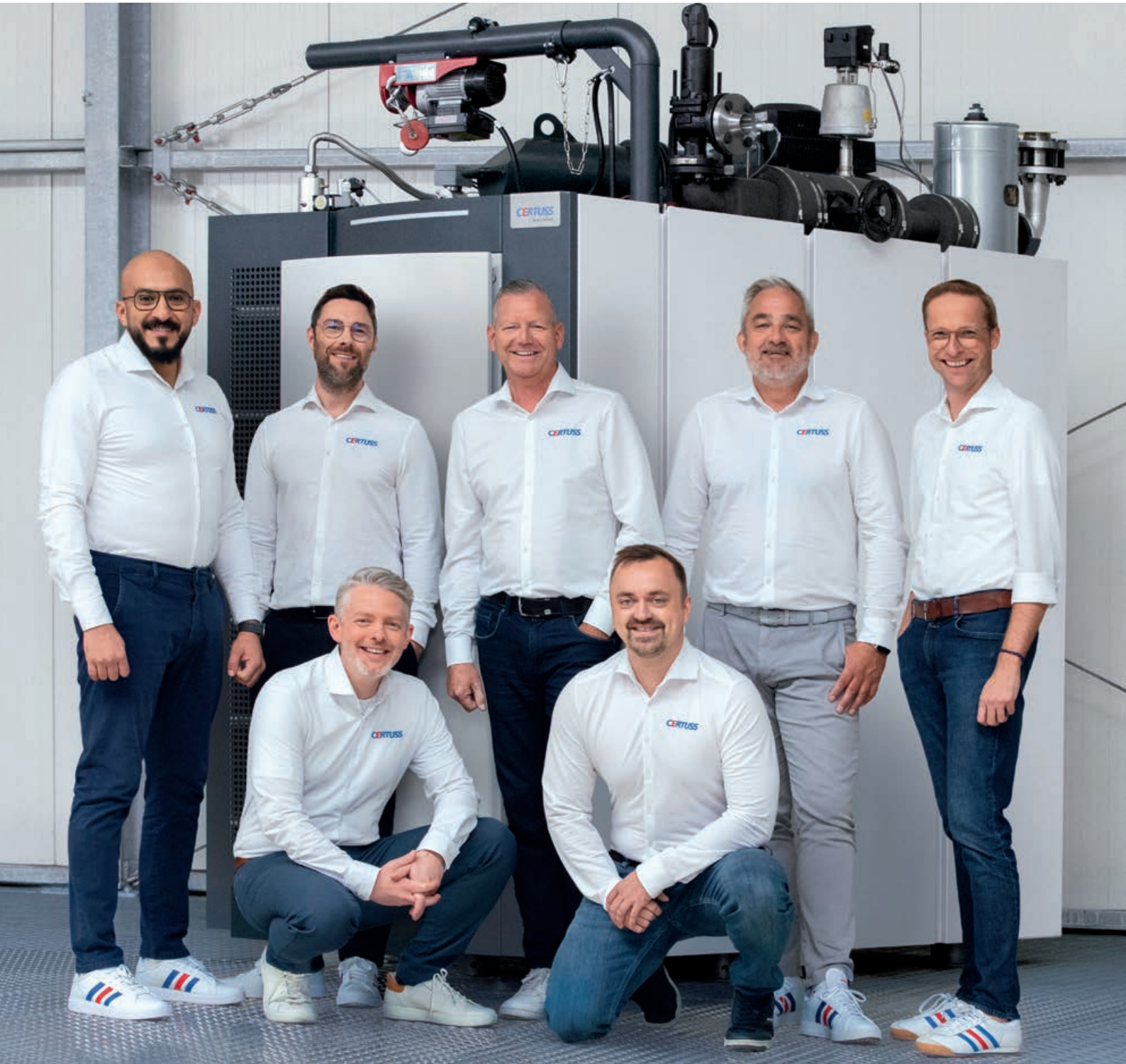

Durable, efficient, low-maintenance steam generators
to increase sustainability

The ideal type



For many years, our designers, engineers, and technicians have been working with an innovative spirit, technical expertise, and attention to detail to achieve the ideal type. We check all components to ensure the highest quality and use only the best. That's why CERTUSS steam generators are easy to operate, require little maintenance, and function reliably for decades. The CERTUSS production area is certified according to quality standard DIN EN ISO 9001:2015, but in many cases our quality requirements are even higher.





System advantages

EASY TO OPERATE

_All configurations and settings are easy to manage with the self-explanatory touchscreen.

DURABLE

_Preheating the feed water to 90° to 95°C separates the oxygen from the water and provides corrosion protection.

NO WAITING TIME

_The CERTUSS heating coil is the core component of the water tube boiler principle. Three minutes after the system is started, the high-speed steam generator is supplying saturated steam.

PRECISE

_The burner, which can be controlled exactly, supplies precisely regulated steam pressure in increments of 1/10 bar.

SAFE

_Based on the water tube boiler principle, much less water is heated than in conventional boilers. That reduces risk to a minimum.

PROTECTED

_The automatic safety valve prevents overpressure.

EFFICIENT

_No heat loss due to the unique 3-fold air insulation and heat recycling. Not only is the combustion air preheated, but the outer covering is cooled as well, which minimizes loss and saves energy. The CERTUSS economizer allows the energy potential of the discharged flue gas to be used as well.



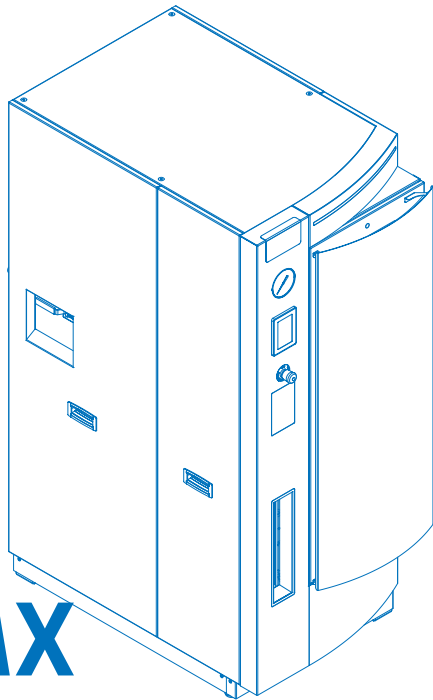

EMX

E10MX – E320MX

**Electric, efficient, compact,
modular, and powerful**

The CERTUSS EMX series – a new performance class in terms of efficiency, load adjustment, and footprint. Electric steam generators are heated by stainless steel heating rods with a large heating surface. The output of the heating elements is regulated continuously via semiconductor contactors. One energy-efficient advantage is the immediate modulating output adjustment to the actual steam demand during the operating cycle.







ELECTRIC WITH A LOW SPACE REQUIREMENT AND THE OPTION TO INCREASE OUTPUT

The EMX steam generators are ready for use 3–5 minutes after starting up the system and the equipment design guarantees continuous regulation of the steam output from 10 to 320 kg/h. Each module can be expanded up to an output of 160 kg/h. The EMX comes in eleven sizes with regard to output.

The compact design decreases the space requirement by up to 25%. Equipment dimensions match the standard door size (80 cm) for efficient assembly and the modular design provides great flexibility because modules can be arranged as desired.



EASY ACCESS [MAINTENANCE ADVANTAGE]

_FLEXIBLE ACCESS POINTS make maintenance quick and easy.

LOW WEAR [LONG LIFE]

_The LONG LIFE DESIGN guarantees high durability, reliability, and long service life.

INSTALLATION [EFFICIENT]

_The optional integrated WATER MODULE MX-CPA simplifies installation and lowers costs.
 _The fully automatic 72-HOUR OPERATION increases efficiency.

CONTROL [PLUS]

_The proven THERMOTIMAT-PLUS CONTROL is optional. It provides corrosion protection; constant boiler pressure and consistent steam quality increase process reliability.

OPERATING PRESSURE [UP TO 16 BAR]

_Safe operating pressure up to 16 BAR guarantees a wide range of applications.

STEAM [QUALITY]

_Steam can be produced for INDUSTRIAL or CULINARY NEEDS based on the application.



HMI [EASY CONTROL]

_The HUMAN-MACHINE INTERFACE guarantees easy, intuitive control in 15 languages.
 _When steam demand varies, the technology enables intelligent pressure adjustment and reduces consumption.
 _It also allows for CONDITION MONITORING and REMOTE SERVICES and meets all of the requirements for Industry 4.0.

ONE VIEW CONTROL [REMOTE CONTROL]

_The LED STATUS DISPLAY and the WATER LEVEL DISPLAY at the front of the equipment provide continuous assurance regarding equipment condition at a glance.

COOLING [INTEGRATED]

_The optional SWITCHING CABINET COOLING FUNCTION ensures operation even at high temperatures.



➤ TECHNICAL DATA
 Page 36 | 37



JUNIOR TC 80 – 400

The fully automatic, safe solution – in the smallest spaces

This series provides a practical solution for any application areas with low steam demand – such as small breweries or pharmaceutical or food production operations. The electronic control system makes the JUNIOR extremely easy to operate. It is especially adept in working situations in which steam is not continually required and it comes with all of the respective safety equipment ready for operation. The combustion management of the newest generation can be programmed for any fuel type. Its compact, vertical, space-saving design makes it perfect for areas with limited space.





CERTUSS
Made in Germany

EFFICIENT LOAD ADJUSTMENT, EASY TO OPERATE, AND PROVEN IN PRACTICE

System operation can be fully automatic when the optional Thermotimat automatic control is installed. Operators are not required. Manual operation is self-explanatory and easy. The operating display provides graphics which make the instructions for start-up and shutdown easy to understand. It also indicates operating status, programming, errors, and messages in any desired language. Remote control and programming can be set up by request.





USER-FRIENDLY

_Self-explanatory TOUCHSCREEN MENU NAVIGATION makes operation significantly simpler.

REMOTE CONTROL AND SERVICE

_Remote programming, control, and access to data via Ethernet, CAN bus, PROFIBUS or GSM/UMTS modem*.
 _Well-known for excellent service, customer service available 24 hours a day, 365 days a year.

ADVANTAGES OF OUR TECHNOLOGY

_Robust all-steel design with double-shell air cooling with no insulation materials.
 _Noise and vibration damping, elastic assembly attachments.
 _Vertical, stress-free, central mounting of the heating system with low-point blow down.

*Additional equipment.

EFFICIENT AND COST-EFFECTIVE

_Extremely high degree of efficiency (up to 98% with exhaust gas heat exchanger) due to 3-FOLD AIR INSULATION together with the simultaneous preheating of combustion air with very low emission losses.
 _Short heating time. Full steam output is achieved within 3-5 minutes.
 _ELECTRONIC COMBUSTION MANAGEMENT and the PILOT FLAME SYSTEM (gas burner) save energy and costs with immediate load adjustment starting at the respective stream demand.

OPERATION AND INSTALLATION

_Fully automatic operation
 _Secure installation without a platform
 _Small space requirement
 _Can be installed in work areas, no boiler house required.
 _Depending on country-specific regulations no permit required for installation and operation.
 _Compatible with all CERTUSS steam generators of the same or different designs.



 **TECHNICAL DATA**
 Page 38 | 39

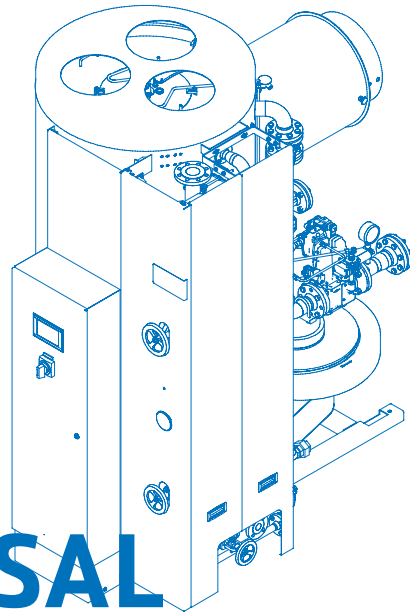

UNIVERSAL TC 500 – 2000

**Economical, highly efficient steam generation –
with greater output by request**

The UNIVERSAL steam generators are the perfect solution for production operations with higher steam demand. The output is flexible and can be adjusted to meet the amount of steam needed. All UNIVERSAL steam generators consist of modules that are completely equipped and ready for operation. They can be combined with each other in a cascade connection and come with an extensive safety package. In comparison with conventional solutions, CERTUSS steam generators require just one-third of the footprint space.







THE SECRET TO CERTUSS QUALITY: INNOVATIVE TECHNOLOGY, THE BEST COMPONENTS, AND METICULOUS CARE

Just as all CERTUSS steam generators, the large series also meets the highest requirements with regard to safety, efficiency, and operational advantages. The intuitive, easily understood control system offers both manual and fully automatic operation without any large personnel or time-related costs. Remote control, programming, and diagnostics are available via various connections.

In case the steam demand increases, the systems are compatible with every CERTUSS series and can be expanded to meet the exact needs.



Greater efficiency with the CERTUSS steam generator housing with 3-fold insulation

EFFICIENT AND COST-EFFECTIVE

- _Extremely high degree of efficiency (up to 98.5% with Economiser) due to 3-FOLD AIR INSULATION together with the simultaneous preheating of combustion air with very low emission losses.
- _Short heating time. Full steam output is achieved within 3–5 minutes.
- _ELECTRONIC COMBUSTION MANAGEMENT and the PILOT FLAME SYSTEM (gas burner) save energy and costs with immediate load adjustment starting at the respective stream demand.
- _Modulating output control from 50% to 100% steam output with GAS BURNER EQUIPMENT (two output increments with oil operation: 50% and 100%).
- _Low-maintenance FEED WATER PUMP with infinitely variable speed regulation.
- _Low-emission burner for each size developed especially to meet the most recent European standards.

OPERATIONAL ADVANTAGES

- _Self-explanatory TOUCHSCREEN MENU NAVIGATION makes operation significantly simpler.
- _THERMOTIMAT AUTOMATIC CONTROL for fully automatic operation*.
- _Remote control and control via Ethernet and mobile networks*.
- _Optional: “CPA” supply unit: a complete boiler house installation including a boiler feed pump, feed water tank, steam separator, water treatment, and wastewater mixing heat exchanger.

*Additional equipment.

INSTALLATION ADVANTAGES

- _Secure installation without a platform
- _Small space requirement
- _Can be installed in work areas, no boiler house required.
- _Depending on country-specific regulations no permit required for installation and operation.
- _Standard versions come with equipment for up to 72 hours of operation without manual invention (water monitoring optional).



➤ TECHNICAL DATA
Page 40 | 41

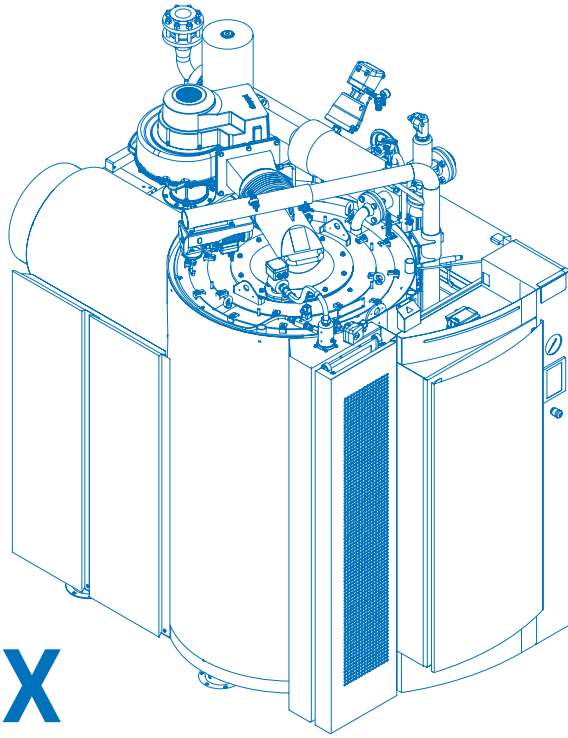

UMX

U1500MX – U2000MX

The new standard with UMX: reduce costs and conserve resources

The UMX on-demand steam generator is completely newly developed and is designed for use with NG or LPG or both (dual gas). The system is ready for operation just 3 to 5 minutes after start-up and allows for continuous modulation between 20% and 100% output. NO_x emissions remain well below the required regulations. With its high efficiency, environmental compatibility, and user-friendly operation, the UMX sets new standards in its class.





EFFICIENCY REDEFINED – THE NEXT GENERATION OF STEAM GENERATORS

In the new UMX model series, features that were previously optional are now included as standard. Components such as the water pump, sliding gate valve, hot water filter, gas filter and steam separator are fully integrated and pre-installed – making the CERTUSS UMX ready for immediate use.

An integrated maintenance chain block hoist, a practical access ladder, and improved service access ensure greater safety and efficiency during maintenance work. The 7-inch display enables convenient operation control – also via connection to a central building management system. Thanks to the innovative One View Control, the device status remains visible at all times – even remotely.





REMOTE CONTROL

_Thanks to ONE VIEW CONTROL, the device status is always in view – and can also be programmed, read or controlled remotely.

INSTALLATION ADVANTAGES

_Everything you need for immediate use is integrated and pre-installed:: WATER PUMP, SLIDING GATE VALVE, HOT WATER FILTER, GAS FILTER and STEAM SEPARATOR.
 _The proven THERMOTIMAT-PLUS CONTROL is now standard equipment.

USER-FRIENDLY

_An optimised SERVICE ACCESS, a pre-assembled CHAIN BLOCK HOIST and an integrated ACCESS LADDER make maintenance work easier, safer and more efficient.

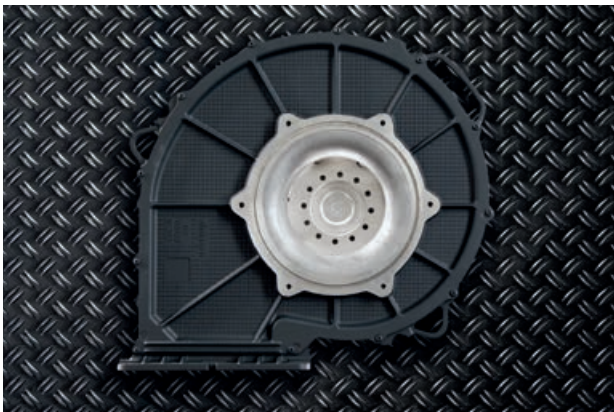

EFFICIENT AND COST-EFFECTIVE

_Short heating time. Full steam output is achieved within 3–5 minutes.
 _Fully modulating 5:1 turndown burner offers continuous modulation between 20% and 100% output.
 _Designed for use with NG or LPG or dual gas (NG/LPG).
 _NOx emissions are well below the required standards.



OPERATION AND INSTALLATION

_Fully automatic operation
 _Secure installation without a platform
 _Small space requirement
 _Can be installed in work areas, no boiler house required.
 _Depending on country-specific regulations no permit required for installation and operation.
 _Compatible with all CERTUSS steam generators of the same or different designs.
 _Hybrid solution possible with electric steam generator EMX.



TECHNICAL DATA
 Page 42 | 43

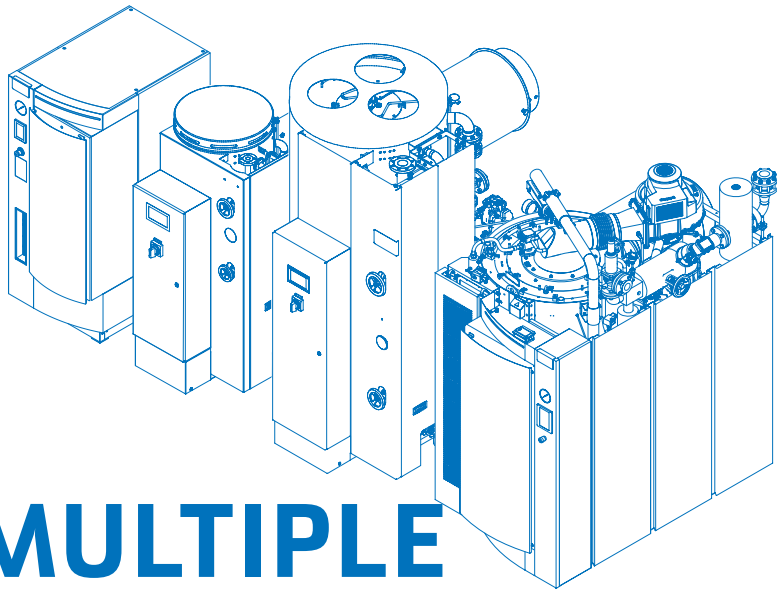

MULTIPLE SYSTEMS

Efficiency means "nothing more than what is needed"

Multiple systems by CERTUSS enable a highly flexible steam supply while saving energy. With the integrated diagnostic system, steam production is ideally distributed between the base-load boiler and the peak-load boiler. This allows needs-oriented operation with a long service life, which is, in turn, sustainable.

Based on technical production conditions, various types of combustion and heating such as gas, oil, or electrical and various output classes can be combined to achieve the ideal solution. As a particularly efficient hybrid solution, the EMX with electric heating and the UMX with fossil fuel combustion can be operated in multiple systems thanks to identical control devices.





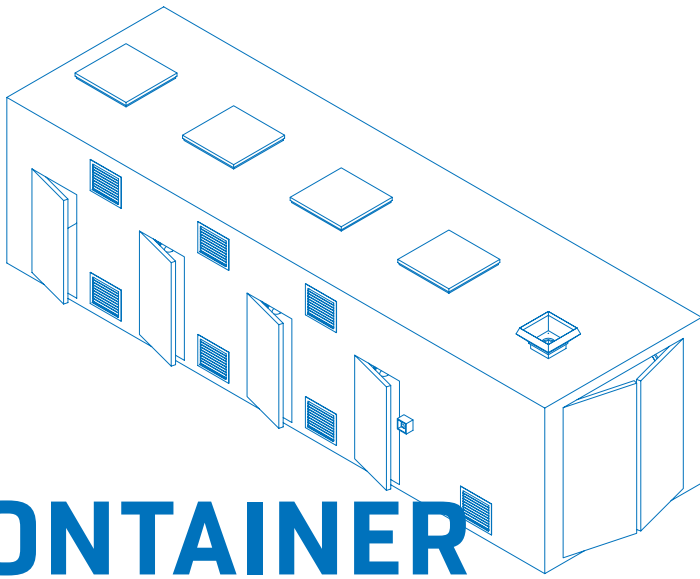

CONTAINER STEAM SYSTEMS

A custom built boiler house ready for operation

When steam production needs to be located outside of buildings or when mobile systems are required, we create the right enclosure solution.

The enclosure includes all of the components for generating steam. Your container design can include flexible adaptations to meet the requirements for your space and production and it will function just as economically as a stationary CERTUSS system. This solution also achieves full steam output within 5 minutes after system start-up.





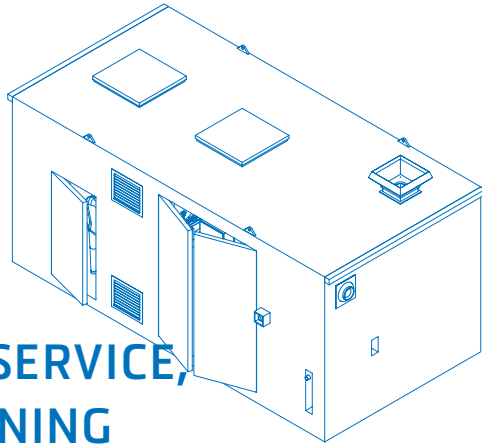

STRONG IN SERVICE, FROM PLANNING TO MAINTENANCE

Your specifications are crucial

Our container steam generators are tailor-made for 80 industries. We can also implement special developments for specific requirements. The systems are easy to operate and can be efficiently adjusted to the required output, while the setup is extra space-saving.

Further advantages of containerized multiple systems include high process and peak load reliability, as well as N+1 redundancy. Maintenance is possible during operation. We supply turnkey, complete systems worldwide.

We would be happy to support you with the commissioning of your steam boiler installation and the instruction of your operators. We also adapt our maintenance and service models to meet your requirements exactly.





CONTAINER ADVANTAGES

- _ Tailored to meet customer requests and specifications
- _ Compact and space-saving
- _ Mechanical and electrical components are all completely preinstalled
- _ High-quality, insulated stainless steel walls to protect the equipment
- _ External paint according to your specifications
- _ Insulated pipe installation inside
- _ Steel or UPVC door as desired
- _ Complete internal lighting
- _ Individual selection of installation location provides the greatest flexibility
- _ No separate boiler house required
- _ Lower costs for on-site installation
- _ Optional air-conditioning for the container

OPTIONAL EQUIPMENT

- _ CERTUSS steam generator(s)
- _ CPA supply unit
- _ Water treatment system
- _ Steam distributor
- _ Pressure reducing station
- _ Steam separator
- _ Condensate lifting system
- _ Air-conditioning
- _ Oil tank
- _ and more



CPA | CERTUSS

PACKAGED ACCESSORIES

The best conditions for durability and steam quality

Consistent water quality is critical for the durability of the steam generator and for the resulting steam quality. The factory-installed CERTUSS CPA ensures the proper supply. It is adapted precisely to meet the respective system and installation situation and can be equipped to handle future increases in required output.

The CPA includes and regulates all of the connections for water, steam, electricity, and energy. The high-quality components for water treatment and supply are compact and are installed such that they are easily accessible and save space.

CERTUSS Flexibility

Every CERTUSS supply unit is configured precisely for current or future demand situations.



Customized prefabrication reduces installation time and costs to a minimum

The entire pipe installation between the steam generator and the supply unit is properly adapted and prefabricated to meet on-site conditions. The same applies for the electrical wiring and the connecting cables for the system. Planning in advance with CAD ensures precision and reliability. These preparations reduce on-site installation time and costs to a minimum.



OPTIONAL EQUIPMENT

- _ Water treatment system, including automatic dosing
- _ Desalination heat exchanger
- _ Feed water tank
- _ Steam separator
- _ Blow down tank
- _ Pre-pressure pump
- _ Testomat (testing device)
- _ Conductivity monitor
- _ Switching cabinet



CPA ADVANTAGES

- _ All supply and water treatment components for CERTUSS steam generators are provided as a complete unit
- _ Low space requirement due to compact design
- _ Proper installation by professional guarantees safe operation
- _ Base frame is powder-coated for corrosion protection
- _ Complete with electrical sub-panel
- _ Easy accessibility and maintenance
- _ Inexpensive series production with elements that are perfectly adapted to each other
- _ Made with approved, high-quality materials
- _ Significant reduction in assembly time saves costs
- _ Factory installation of all connections for water, steam, electricity, and energy ensures safety



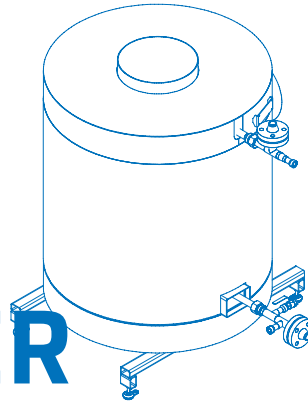

ECONOMISER CERTECON 80-2000

Efficiency that pays off and reduces CO₂

Flue gas heat exchangers increase the efficiency and reduce the CO₂ emissions of CERTUSS steam generators heated by oil or gas. CERTECON flue gas heat exchangers use the heat from exhaust gas to increase the temperature of the feed water. This achieves heat recycling of up to 43 kW, which increases efficiency and reduces fuel consumption.



ECONOMISER

SPI 500 – 2000

Lower energy consumption – higher efficiency

Depending on the gas-heated or oil-heated CERTUSS steam generator in use and the installation situation, this flue gas heat exchanger helps to reduce fuel consumption significantly while increasing efficiency. Heat recycling of up to 83 kW is possible.

Our team would be happy to discuss the details with you.

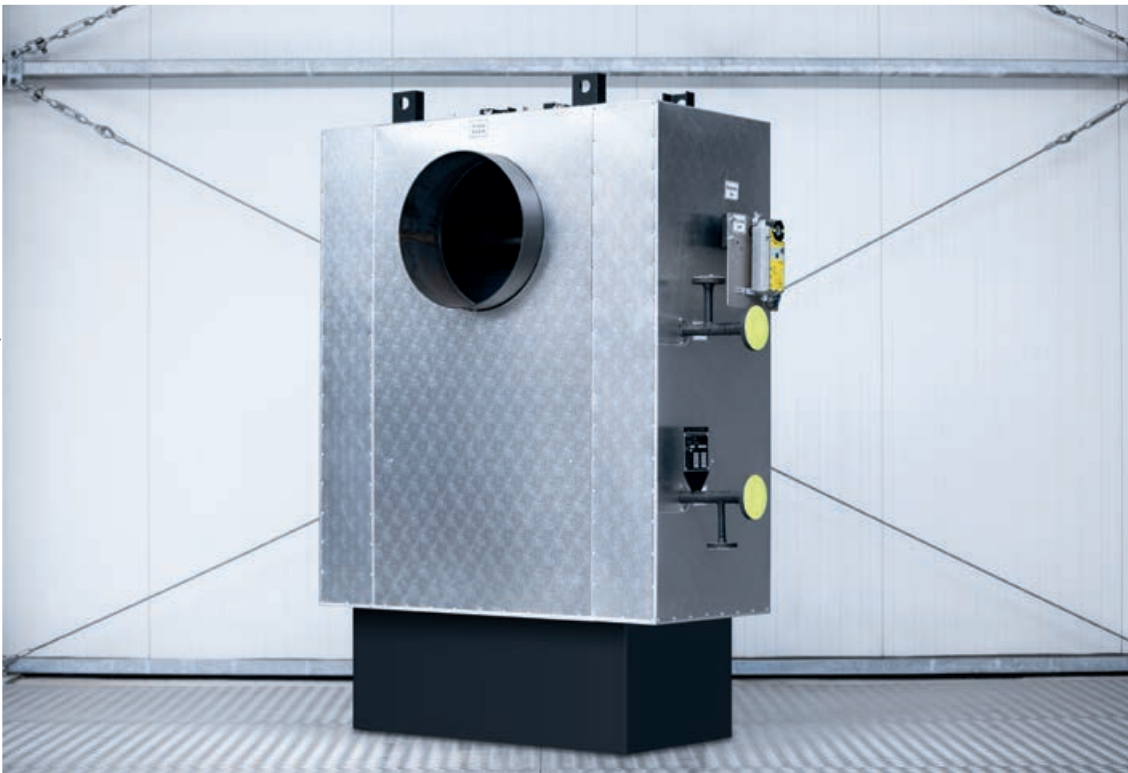

[➤ TECHNICAL DATA](#)
Page 44 | 45

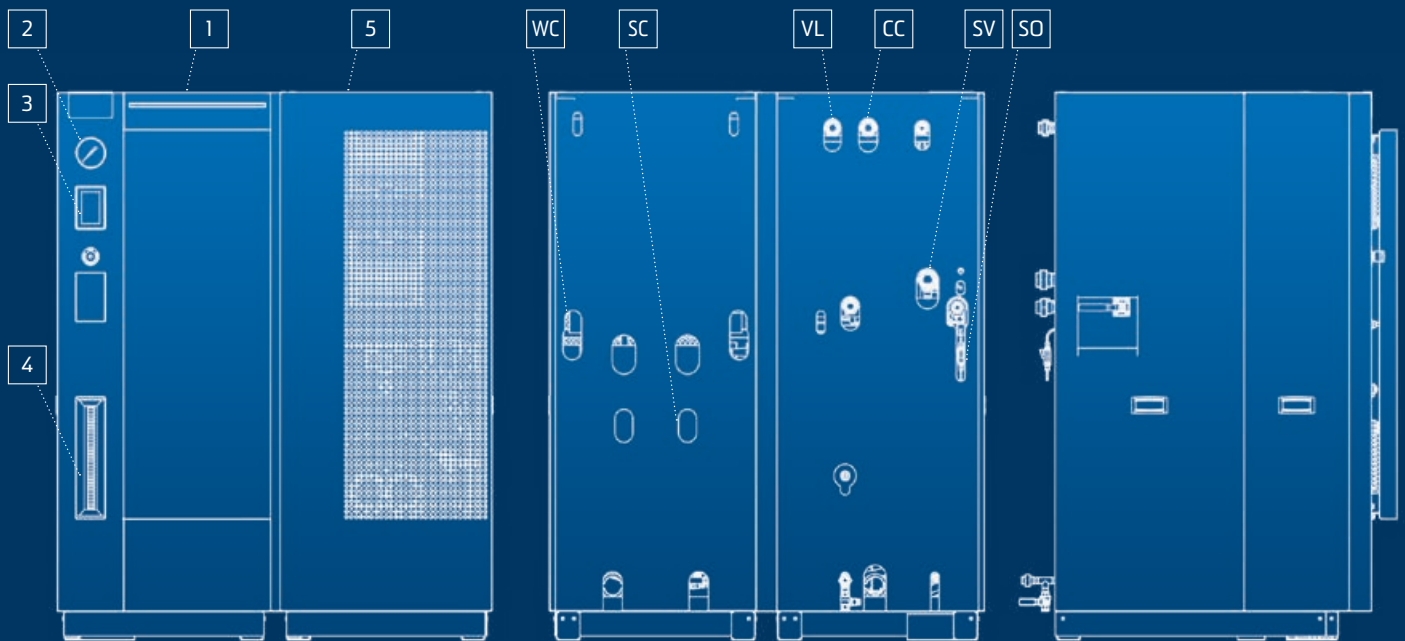

- 1 Model Electrical E160MX
- 2 Pressure gauge
- 3 Touchscreen
- 4 Level indicator
- 5 Supply unit MX-CPA

- SO Steam outlet
- SV Safety valve to the outside
- VL Vapor vent line to the outside
- WC Water connection
- CC Condensate connection
- SC Sewer connection

EMX

E10MX – E320MX

| Model E-MX | | 10 | 20 | 40 | 60 | 80 | 100 | 130 | 160 | 200 | 260 | 320 | | |
|--|-------------|---|------|------|------|----------------|--------|-------|-------|--------------------|-------|-------|--|--|
| Capacities | | | | | | | | | | | | | | |
| Steam output | kg/h | 10 | 20 | 40 | 60 | 80 | 100 | 130 | 160 | 200 | 260 | 320 | | |
| Heat output | kW | 8 | 16 | 32 | 48 | 67 | 80 | 107 | 120 | 160 | 200 | 240 | | |
| Electrical output | kW | 8.7 | 16.7 | 32.7 | 48.7 | 67.7 | 80.7 | 107.7 | 120.7 | 160.7 | 200.7 | 240.7 | | |
| Water content | l | 37 (NV = 18.5) | | | | 45 (NV = 28.9) | | | | 89 (NV = 56.7) | | | | |
| Operating voltage | | 380 – 480 V · 50/60 Hz | | | | | | | | | | | | |
| Pressures | | | | | | | | | | | | | | |
| Operating pressure min./max. | MPa (bar) | 0.3 / 0.35 (3.0 / 3.5) · 0.35 / 0.55 (3.5 / 5.5) · 0.35 / 0.9 (3.5 / 9.0) · 0.35 / 1.1 (3.5 / 11.0) · 0.35 / 1.18 (3.5 / 11.8) · 0.35 / 1.45 (3.5 / 14.5) | | | | | | | | | | | | |
| Max. permissible overpressure | MPa (bar) | 0.4 (4) · 0.6 (6) · 1.0 (10) · 1.2 (12) · 1.3 (13) · 1.6 (16) | | | | | | | | | | | | |
| Materials | | | | | | | | | | | | | | |
| Pressure vessel | | P235GH / Stainless steel (AISI 316 Ti) | | | | | | | | | | | | |
| Feed water tank | | Stainless steel (AISI 316 Ti) | | | | | | | | | | | | |
| Armatures | | Brass / Stainless steel (AISI 316L/AISI 316 Ti) | | | | | | | | | | | | |
| Housing | | S235JR / Stainless steel (AISI 304) | | | | | | | | | | | | |
| Measures and weight | | | | | | | | | | | | | | |
| Dimensions (H x W x D) | mm | 1900 x 774 x 1150 | | | | | | | | 1900 x 1580 x 1150 | | | | |
| Operating weight | kg | 520 | | | | | 630 | | | 960 | | | | |
| The following services are incurred depending on the design | | | | | | | | | | | | | | |
| Electrical power control voltage 230 VAC (option MX-CPA) | kW | | | | | | | 0.25 | | | | | | |
| Electrical power cooling unit | kW | | | | | | 0.95 | | | 1.45 | | | | |
| Electrical power feed water heating | kW | | | | | | 9 / 18 | | | 9 / 18 / 27 / 36 | | | | |
| Connections | | | | | | | | | | | | | | |
| Steam outlet | | | | | | | | 1/2" | | | 1" | | | |
| Soft water connection | | | | | | | | 1/2" | | | | | | |
| Safety valve | 4 – 6 bar | | | | | | 1" | | | 1 1/4" | | | | |
| | 10 – 13 bar | | | | | | 1" | | | 1" | | | | |
| | 16 bar | | | | | | 1" | | | 1 1/4" | | | | |
| Blow down/desalination line | DN | | | | | | | 1/2" | | | | | | |
| Overflow/drainage feed water tank | DN | | | | | | | 1" | | | | | | |
| Condensate return | DN | | | | | | | 1" | | | | | | |
| Vapor vent line | DN | | | | | | | 1" | | | | | | |
| Volume | | | | | | | | | | | | | | |
| Feed water tank | V | 45.5 ltr. | | | | | | | | | | | | |
| Categorization EPEG 2014/68/EU | | | | | | | | | | | | | | |
| EPEG category | 4 bar | | | | | | II | | | III | | | | |
| | 6 – 16 bar | | | | | | III | | | III | | | | |

Dimensions and weights have been rounded up or down. MPa and bar are overpressure values. Performance values referenced to 10 °C feed-water temperature and 0.6 MPa (6 bar) steam overpressure.

Right to technical revision reserved.

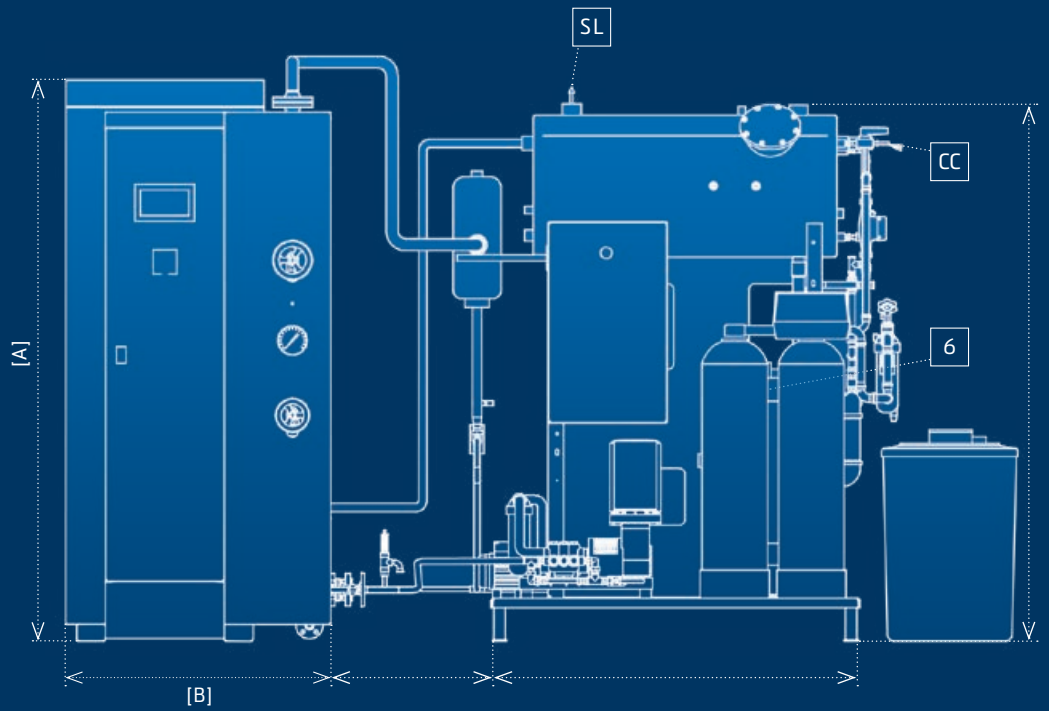

- 1 Model JUNIOR TC
- 2 CPA supply unit
- 3 Pre-pressure pump
- 4 Feed water pump
- 5 Feed water tank
- 6 Mixing heat exchanger
- 7 Dosing device
- 8 Water softening system
- 9 Brine tank
- 10 Switching cabinet
- 11 Steam separator

- SC Steam connection
- WC Water connection
- VL Vapor vent line to the outside
- SV Safety valve to the outside
- SC Sewer connection
- CC Condensate connection
- FC Fuel connection

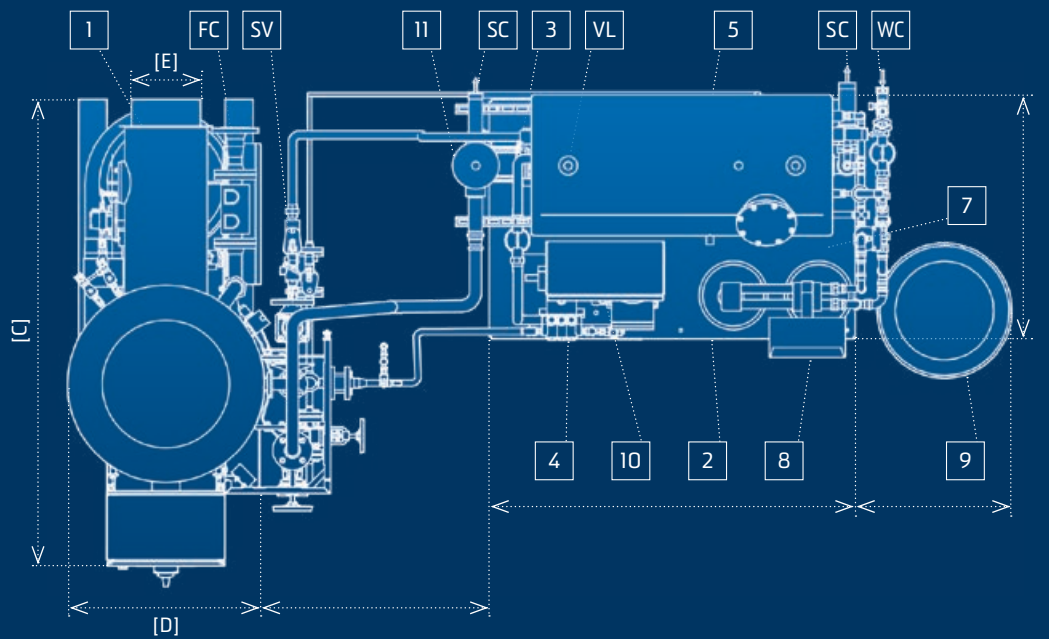

JUNIOR

TC 80 – 400

| Model JUNIOR | | 80 | 120 | 150 | 200 | 250 | 300 | 350 | 400 |
|---------------------------------------|-------------------|-----------------------------------|-----|------------------------------|------|------------------------------|------|------|------|
| Size | | 1 | | 2 | | 3 | | | |
| Capacities | | | | | | | | | |
| Steam output | kg/h | 80 | 120 | 150 | 200 | 250 | 300 | 350 | 400 |
| Heating capacity | kW | 52 | 79 | 98 | 131 | 164 | 197 | 230 | 262 |
| Nominal load | kW | 58 | 87 | 109 | 145 | 182 | 218 | 254 | 291 |
| Levels | | | | | | | | | |
| Pressures | | | | | | | | | |
| Min. / max. operating pressure | MPa (bar) | 0.6 (6) / 0.8 – 2.9 (8 – 29) | | 0.6 (6) / 0.8 – 2.9 (8 – 29) | | 0.6 (6) / 0.8 – 2.9 (8 – 29) | | | |
| Max. permissible overpressure | MPa (bar) | 1.0 – 3.2 (10 – 32) | | 1.0 – 3.2 (10 – 32) | | 1.0 – 3.2 (10 – 32) | | | |
| Consumption | | | | | | | | | |
| Natural gas | m ³ /h | 5.8 | 8.7 | 10.9 | 14.5 | 18.2 | 21.8 | 25.4 | 29.1 |
| Liquid gas | m ³ /h | 2.3 | 3.4 | 4.2 | 5.6 | 7.0 | 8.5 | 9.9 | 11.3 |
| Heating oil (EL) | kg/h | 4.9 | 7.4 | 9.2 | 12.3 | 15.3 | 18.4 | 21.5 | 24.5 |
| Dimensions | | | | | | | | | |
| Height A | mm | 1515 | | 1600 | | 1850 | | | |
| Width B | mm | 730 | | 770 | | 875 | | | |
| Depth C | mm | 1295 | | 1475 | | 1580 | | | |
| Boiler ø D | mm | 500 | | 560 | | 640 | | | |
| Flue gas pipe ø E | mm | 180 | | 200 | | 250 | | | |
| Flue gas center F | mm | 1050 | | 1120 | | 1360 | | | |
| Weight | kg | 320 | | 420 | | 520 | | | |
| Connections | | | | | | | | | |
| Electrical connection load | kVA | 3.33 | | 3.37 | | 3.92 | | | |
| Oil connection | DN | 3/8" | | 3/8" | | 3/8" | | | |
| Natural gas | DN | 20 | | 32 | | 40 | | | |
| Liquid gas | DN | 20 | | 20 | | 25 | | | |
| Feed water | DN | 1 1/4" | | 1 1/4" | | 1 1/4" | | | |
| Steam connection | DN | 15 | | 20 | | 25 | | | |
| Safety valve | DN | 1" | | 40 | | 40 | | | |
| Start-up line | DN | 3/4" | | 3/4" | | 1" | | | |
| Categorization EPEG 2014/68/EU | | | | | | | | | |
| EPEG category | | up to 16 bar II / 25 – 32 bar III | | III | | | | | |

Reference values: natural gas 10 kWh/Nm³, liquid gas 25.8 kWh/Nm³, heating oil (EL) 11.86 kWh/kg. Dimensions and weights have been rounded up or down.
*MPa and bar are overpressure values. Performance values referenced to 100 °C feed-water temperature and 1 MPa (10 bar) steam overpressure.

Right to technical revision reserved.

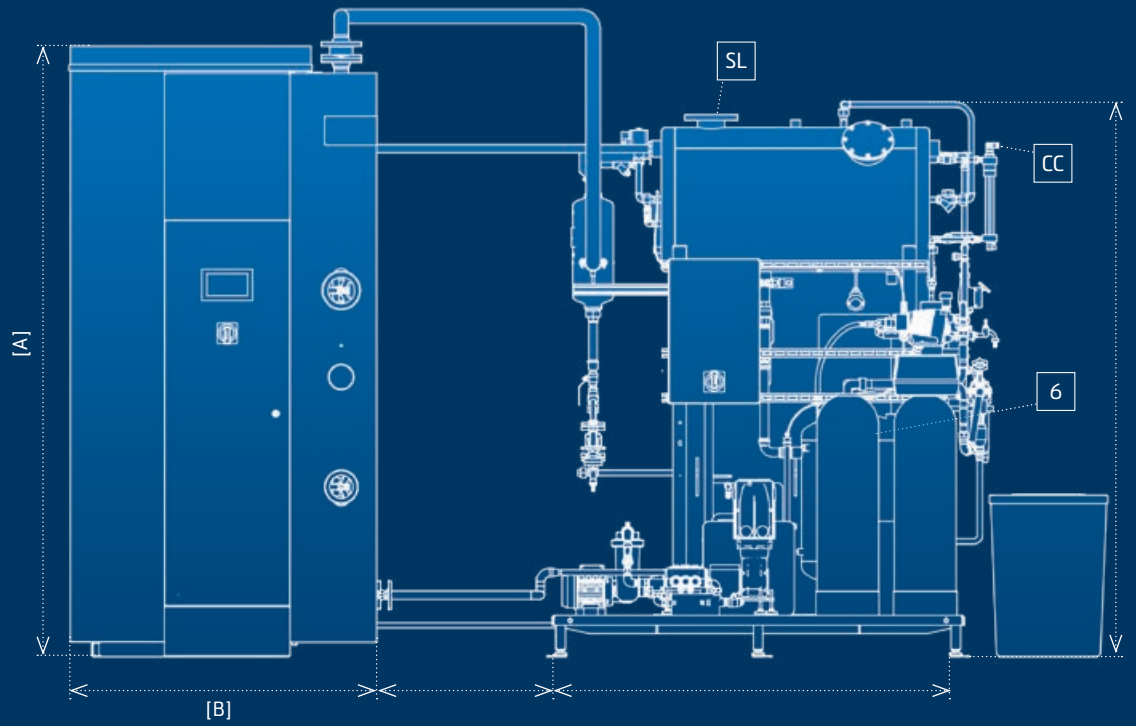

- 1 Model UNIVERSAL TC
- 2 CPA supply unit
- 3 Pre-pressure pump
- 4 Feed water pump
- 5 Feed water tank
- 6 Mixing heat exchanger
- 7 Dosing device
- 8 Water softening system
- 9 Brine tank
- 10 Switching cabinet
- 11 Steam separator

- SC Steam connection
- WC Water connection
- VL Vapor vent line to the outside
- SV Safety valve to the outside
- SC Sewer connection
- CC Condensate connection
- FC Fuel connection

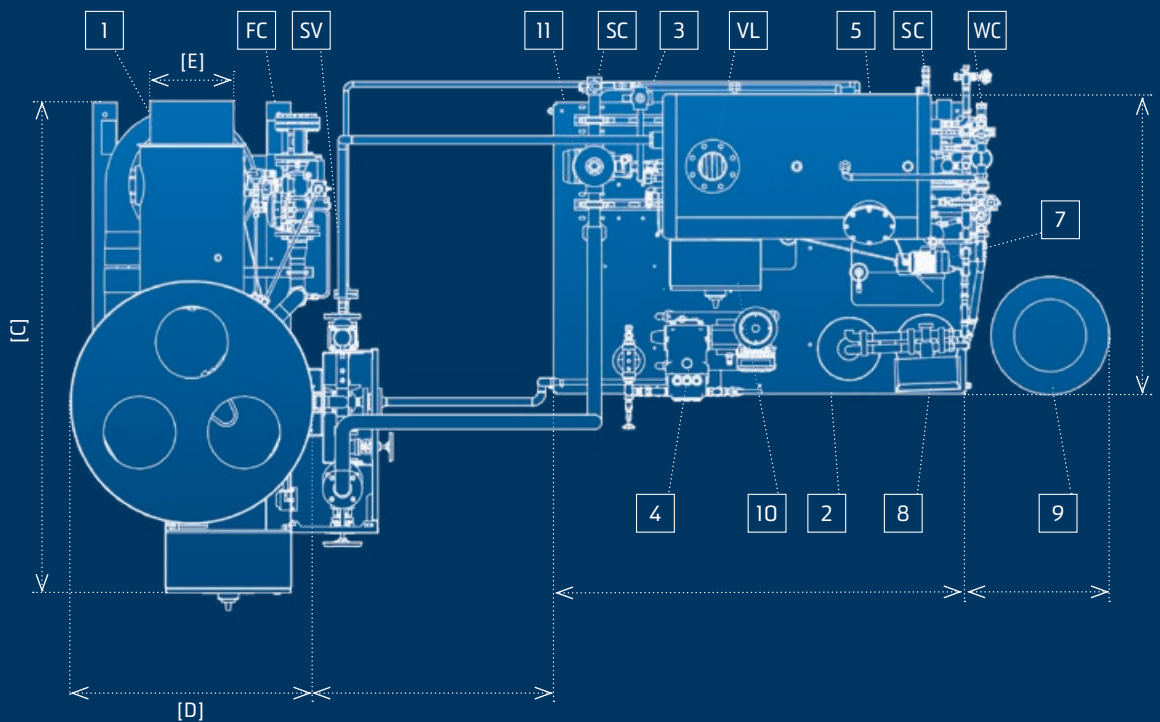

UNIVERSAL TC 500 – 2000

| Model UNIVERSAL | | 500 | 600 | 700 | 850 | 1000 | 1300 | 1500 | 1800 | 2000 |
|---------------------------------------|-------------------|------------------------------|------|------------------------------|------|-----------------------------------|------|-----------------------------------|-------|-------|
| Size | | 4 | | 5 | | 6 | | 7 | | |
| Capacities | | | | | | | | | | |
| Steam output | kg/h | 500 | 600 | 700 | 850 | 1000 | 1300 | 1500 | 1800 | 2000 |
| Heating capacity | kW | 328 | 394 | 459 | 558 | 656 | 853 | 984 | 1181 | 1312 |
| Nominal load | kW | 364 | 436 | 509 | 618 | 727 | 945 | 1091 | 1309 | 1454 |
| Stages | | 2 | | 2 | | 2 | | 2 | | |
| Pressures | | | | | | | | | | |
| Min. / max. operating pressure | MPa (bar) | 0.6 (6) / 0.8 – 3.0 (8 – 30) | | 0.6 (6) / 0.8 – 2.9 (8 – 29) | | 0.6 (6) / 0.8 – 2.9 (8 – 29) | | 0.6 (6) / 0.8 – 2.9 (8 – 29) | | |
| Max. permissible overpressure | MPa (bar) | 1.0 – 3.2 (10 – 32) | | 1.0 – 3.2 (10 – 32) | | 1.0 – 3.2 (10 – 32) | | 1.0 – 3.2 (10 – 32) | | |
| Consumption | | | | | | | | | | |
| Natural gas | m ³ /h | 36.4 | 43.6 | 50.9 | 61.8 | 72.7 | 94.5 | 109.1 | 130.9 | 145.4 |
| Liquid gas | m ³ /h | 14.1 | 16.9 | 19.7 | 24.0 | 28.2 | 36.6 | 42.3 | 50.7 | 56.4 |
| Heating oil (EL) | kg/h | 30.6 | 36.8 | 42.9 | 52.1 | 61.3 | 79.7 | 91.9 | 110.3 | 122.6 |
| Dimensions | | | | | | | | | | |
| Height A | mm | 1985 | | 2290 | | 2535 | | 2675 | | |
| Width B | mm | 955 | | 1160 | | 1275 | | 1420 | | |
| Depth C | mm | 1725 | | 1930 | | 2125 | | 2415 | | |
| Boiler ø D | mm | 700 | | 870 | | 1000 | | 1100 | | |
| Flue gas pipe ø E | mm | 250 | | 300 | | 350 | | 500 | | |
| Flue gas center F | mm | 1460 | | 1750 | | 1940 | | 2025 | | |
| Weight | kg | 950 | | 1100 | | 1500 | | 2300 | | |
| Connections | | | | | | | | | | |
| Electr. connection gas | kVA | 5.66 | | 6.71 | | 12.53 | | 17.86 | | |
| Electr. connection oil/comb. | kVA | 6.63 | | 7.68 | | 13.50 | | 18.83 | | |
| Oil connection | DN | 3/8" | | 3/8" | | 3/8" | | 1/2" | | |
| Natural gas | DN | 50 | | 65 | | 65 | | 80 | | |
| Liquid gas | DN | 25 | | 40 | | 40 | | 50 | | |
| Feed water | DN | 1 1/4" | | 1 1/4" | | 1 1/4" | | 1 1/4" | | |
| Steam connection | DN | 32 | | 40 | | 50 | | 65 | | |
| Safety valve | DN | 40 | | 40 | | 40 | | 50 | | |
| Start-up line | DN | 3/4" | | 1" | | 1 1/2" | | 1 1/2" | | |
| Categorization EPEG 2014/68/EU | | | | | | | | | | |
| EPEG category | | III | | up to 25 bar III / 32 bar IV | | up to 16 bar III / 25 – 32 bar IV | | up to 16 bar III / 25 – 32 bar IV | | |

Reference values: natural gas 10 kWh/Nm³, liquid gas 25.8 kWh/Nm³, heating oil (EL) 11.86 kWh/kg. Dimensions and weights have been rounded up or down.
*MPa and bar are overpressure values. Performance values referenced to 100 °C feed-water temperature and 1 MPa (10 bar) steam overpressure.

Right to technical revision reserved.

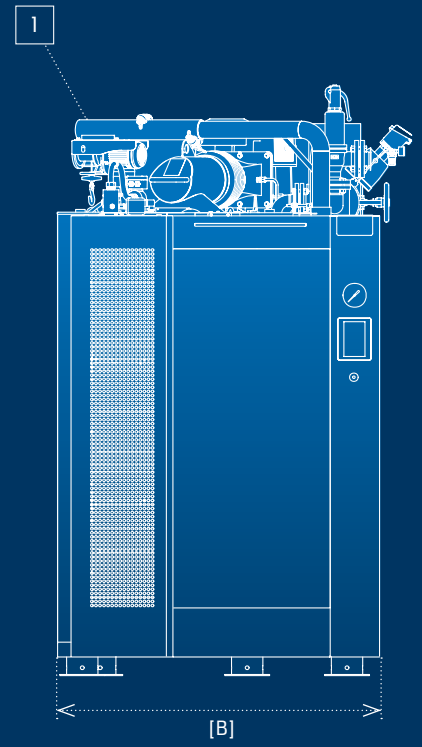
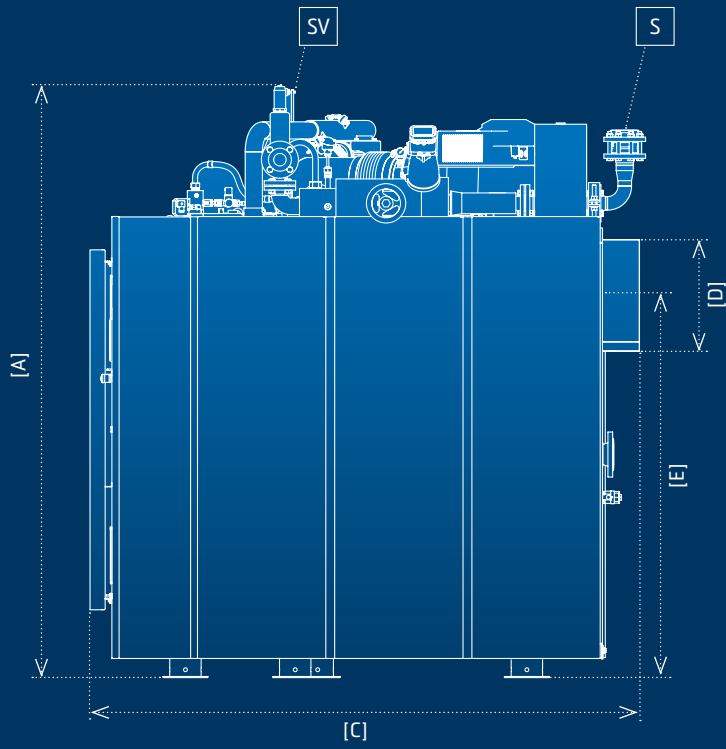

- 1 Model UMX
- A Height
- B Width
- C Depth
- D Flue Gas Pipe \varnothing
- E Flue Gas Center
- S Steam
- F Feedwater
- SV Safety Valve
- NG Natural Gas Train
- LPG LP Gas Train

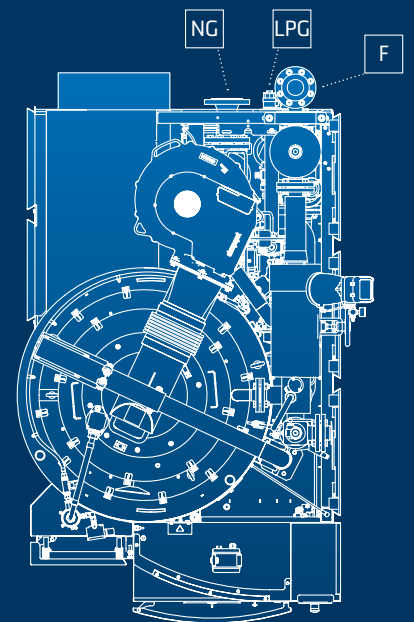

UMX

U1500MX – U2000MX

| Model UMX | | 1500 | 1800 | 2000 |
|---------------------------------|--------------------|---------------------------|---|---------------------------|
| Capacities | | | | |
| Steam output | kg/h | 1500 | 1800 | 2000 |
| Heat output ¹ | kW | 984 | 1181 | 1312 |
| Firing rate | kW | 218 – 1091 (20 – 100 %) | 262 – 1309 (20 – 100 %) | 291 – 1454 (20 – 100 %) |
| Modulation | | | 20 – 100 % (1:5) | |
| Water content | l | | 225.0 | |
| Heating surface | m ² | | 30.7 | |
| Pressures | | | | |
| Operating pressure min./max. | MPa (bar) | | 0.6 (6) / 0.8 – 2.9 (8 – 29) | |
| Max. permissible overpressure | MPa (bar) | | 1.0 – 3.2 (10 – 32) | |
| Combustion NG | | | | |
| Fuel volume flow | Nm ³ /h | 21.8 – 109.1 (20 – 100 %) | 26.2 – 130.9 (20 – 100 %) | 29.1 – 145.4 (20 – 100 %) |
| NOx-emission ² | ppm | | 25 (4.5%) · 13 (5.5%) · 6 (6.5%) · 2 (7.5%) | |
| Combustion LPG (Propane) | | | | |
| Fuel volume flow | Nm ³ /h | 8.5 – 42.3 (20 – 100 %) | 10.1 – 50.7 (20 – 100 %) | 11.3 – 56.4 (20 – 100 %) |
| NOx-emission ² | ppm | | 40 (5.5%) · 13 (6.5%) · 8 (7.5%) | |
| Measures | | | | |
| Height A | mm | | 2632 | |
| Width B | mm | | 1435 | |
| Depth C | mm | | 2442 | |
| Flue gas pipe ø D | mm | | 500 | |
| Flue gas center E | mm | | 1702 | |
| Weight | kg | | 2625 | |
| Connections | | | | |
| Compressed air inlet | DN | | 1/4" | |
| Natural gas train inlet | DN | | 80 | |
| LP gas train inlet | DN | | 50 | |
| Feedwater inlet | DN | | 1 1/4" | |
| Start up | DN | | 1" | |
| Steam outlet | DN | | 65 | |
| Safety valve | DN | | 32 x 50 (Eingang x Ausgang) | |
| Condensate line | DN | | 1/2" | |
| Blowdown | DN | | 25 | |
| Dewatering | DN | | 1/2" | |
| Categories | | | | |
| Max. permissible overpressure | MPa (bar) | | 1.0 – 3.2 (10 – 32) | |
| Category accord. to BetrSichV | | | IV | |
| Category according to PED | | | up to 13 bar III / 16 – 32 bar IV | |
| Volume steam pressure system | ltr | | 225 | |
| Pressure-liter product | ltr. bar | | 2250.0 – 7200.0 | |

1) according to 100 °C feed water temperature and 1.0 Mpa (10 bar) steam pressure

2) based on 4.5% O₂

Right to technical revision reserved.

ECONOMISER

CERTECON 80 – 650

| CERTECON | 80 – 120 | | 150 – 200 | | | | 250 – 650 | | | | |
|--|----------|---------|-----------|---------|-------|---------|-----------|-----|-----|-------|-----|
| CERTUSS Steam generator – Type | | | JUNIOR | | | | UNIVERSAL | | | | |
| | 80 | 120 | 150 | 200 | 250 | 300 | 350 | 400 | 500 | 600 | |
| Dimensions | | | | | | | | | | | |
| Flue gas inlet ø internal | mm | 180 | 200 | | 250 | | | | | | |
| Flue gas outlet ø external | mm | 178 | 198 | | 248 | | | | | | |
| Centre-to-centre distance connecting pieces | mm | 220 | 270 | | 350 | | | | | | |
| Outer diameter | mm | 250 | 280 | | 370 | | | | | | |
| Installation length | mm | 590 | 640 | | 740 | | | | | | |
| Connections¹ | | | | | | | | | | | |
| Water inlet/outlet PN 100 | DN | 15 | | | | 20 | | | | | |
| Nominal width condensate connection | DN | | | | | 1/2" | | | | | |
| Capacities¹ | | | | | | | | | | | |
| Heat output at full load up to | kW | 0.9 | 1.5 | 1.5 | 4.0 | 4.0 | 4.5 | 5.0 | 5.5 | 6.0 | 7.0 |
| Connected burner output max. | kW | 58 | 87 | 109 | 145 | 182 | 218 | 255 | 291 | 364 | 436 |
| Heating flue gas temperature max. | °C | | | | | 350 | | | | | |
| Other data¹ | | | | | | | | | | | |
| Weight without water filling | kg | 24 | 33 | | 66 | | | | | | |
| Pressure equipment volume V | l | 1.49 | 3.16 | | 5.66 | | | | | | |
| Operating overpressure PS | bar | 10 – 40 | 10 – 13 | 16 – 32 | 40 | 10 – 32 | | | | 40 | |
| Product PS x V | max. | 59.6 | 41.08 | 101.12 | 126.4 | 181.12 | | | | 226.4 | |
| PED [DGRL] 2014/68/EU, Annex II, diagram 5, category | | GIP | I | II | IV | II | | | | IV | |

CERTECON 700 – 2000

| CERTECON | 700 – 960 | | 1000 – 1300 | | 1500 – 2000 | |
|--|-----------|---------|-------------|---------|-------------|---------|
| CERTUSS Steam generator – Type | | | UNIVERSAL | | | |
| | 700 – 850 | | 1000 – 1300 | | 1500 – 2000 | |
| Dimensions | | | | | | |
| Flue gas inlet ø internal | mm | 300 | 350 | | 500 | |
| Flue gas outlet ø external | mm | 295 | 345 | | 495 | |
| Connecting piece distance | mm | 850 | 900 | | 940 | |
| Distance floor / connecting piece | mm | | | 355 | | |
| Height | mm | 1325 | 1385 | | 1450 | |
| Diameter | mm | 900 | 1020 | | 1100 | |
| Connections¹ | | | | | | |
| Water inlet/outlet PN 100 | DN | 25 | | 32 | | |
| Desliming | DN | 15 | | 25 | | |
| Dewatering flue gas condensate | | | | 3/4" | | |
| Capacities¹ | | | | | | |
| Heat output at full load up to | kW (ca.) | 15 | 25 | | 43 | |
| Connected burner output max. | kW | 730 | 1100 | | 1480 | |
| Heating flue gas temperature max. | °C | | | 350 | | |
| Other data¹ | | | | | | |
| Weight without water filling | kg | 320 | 387 | | 442 | |
| Pressure equipment volume V | l | 43.1 | 51.6 | | 71.6 | |
| Operating overpressure PS | bar | 10 – 32 | 40 | 10 – 32 | 40 | 10 – 32 |
| Product PS x V | max. | 1379.2 | 1724 | 1651.2 | 2064 | 2291.2 |
| 2864 | | | | | | |
| PED [DGRL] 2014/68/EU, Annex II, diagram 5, category | | III | IV | III | IV | III |
| | | | | | | IV |



ECONOMISER SPI 500–2000

| Size Model UNIVERSAL | 500 | 600 | 700 | 850 | 1000 | 1300 | 1500 | 1800 | 2000 | |
|---|-------------------|------|-----------|------|-----------|------|-----------|------|------|------|
| Artikel-Nr. | 33.0018.1 | | 33.0018.2 | | 33.0018.4 | | 33.0018.6 | | | |
| Dimensions | | | | | | | | | | |
| Equipment height | mm | 1830 | | 2145 | | 2360 | | 2520 | | |
| Equipment width with insulation | mm | 1360 | | 1360 | | 1460 | | 1660 | | |
| Equipm. depth across flue gas connections | mm | 860 | | 860 | | 880 | | 900 | | |
| Internal Ø, flue gas inlet | mm | 255 | | 305 | | 355 | | 505 | | |
| External Ø, flue gas outlet | mm | 245 | | 295 | | 345 | | 495 | | |
| Floor to center of flue gas inlet/outlet | mm | 1460 | | 1750 | | 1940 | | 2025 | | |
| Floor to center of water inlet | mm | 875 | | 990 | | 1160 | | 1165 | | |
| Clear width (internal housing dimensions) | mm | 600 | | | | 700 | | 900 | | |
| Spacing, feed water connections | mm | 375 | | | | 525 | | | | |
| NV, feed water connections PN40 (Mat. 16Mo3) | mm | | | 25 | | | | 32 | | |
| Height, substructure | mm | 312 | | 427 | | 597 | | 592 | | |
| Weight | kg | 550 | | 650 | | 720 | | 860 | | |
| Capacities¹⁾ | | | | | | | | | | |
| Heat output at full load up to | kW | 21 | 25 | 32 | 38 | 45 | 55 | 66 | 76 | 83 |
| Heating surface | m ² | 15 | | 20 | | 24 | | 31 | | |
| Pressure loss, flue gas side max. | mbar | 0.2 | 0.3 | 0.5 | 0.7 | 0.7 | 1.1 | 0.9 | | |
| Flue gas volume, flue gas side | m ³ | 0.28 | | 0.33 | | 0.42 | | 0.63 | | |
| Flow rate, water side | m ³ /h | 0.5 | 0.6 | 0.7 | 0.85 | 1.0 | 1.3 | 1.5 | 1.8 | 2.0 |
| Pressure loss, water side | bar | 0.01 | | 0.02 | | 0.03 | 0.05 | 0.07 | 0.10 | 0.12 |

¹⁾ Values can deviate depending on the burner output, operating overpressure, and capacity utilization of the steam generator.

Right to technical revision reserved.

WE'D BE HAPPY TO ASSIST YOU



HOLGER DEIMANN
Director Sales & Marketing
+49 (0) 2151 578-190
h.deimann@certuss.com



STEFAN DERKS
Sales – Germany,
West / North
+49 (0) 2151 578-229
s.derks@certuss.com



KERSTEN MANKO
Sales – Germany,
South
+49 (0) 2151 578-242
k.manko@certuss.com



GABOR NEUHERZ
Sales – Germany,
East / North
+49 (0) 2151 578-145
g.neuherz@certuss.com



CHRISTIAN LEMMER
Project Management
& Order Processing
+49 (0) 2151 578-263
c.lemmer@certuss.com



DOMINIC PUST
Project Management
& Order Processing
+49 (0) 2151 578-177
d.pust@certuss.com



ISLAM HASSAN
Regional Sales Manager
GCC & MENA
+20 100 996 1899
i.hassan@certuss.com



WESLEY THOMPSON
Regional Sales Manager
United Kingdom & Ireland
+44 (0) 121 327 5362
wesley.thompson@certuss.co.uk



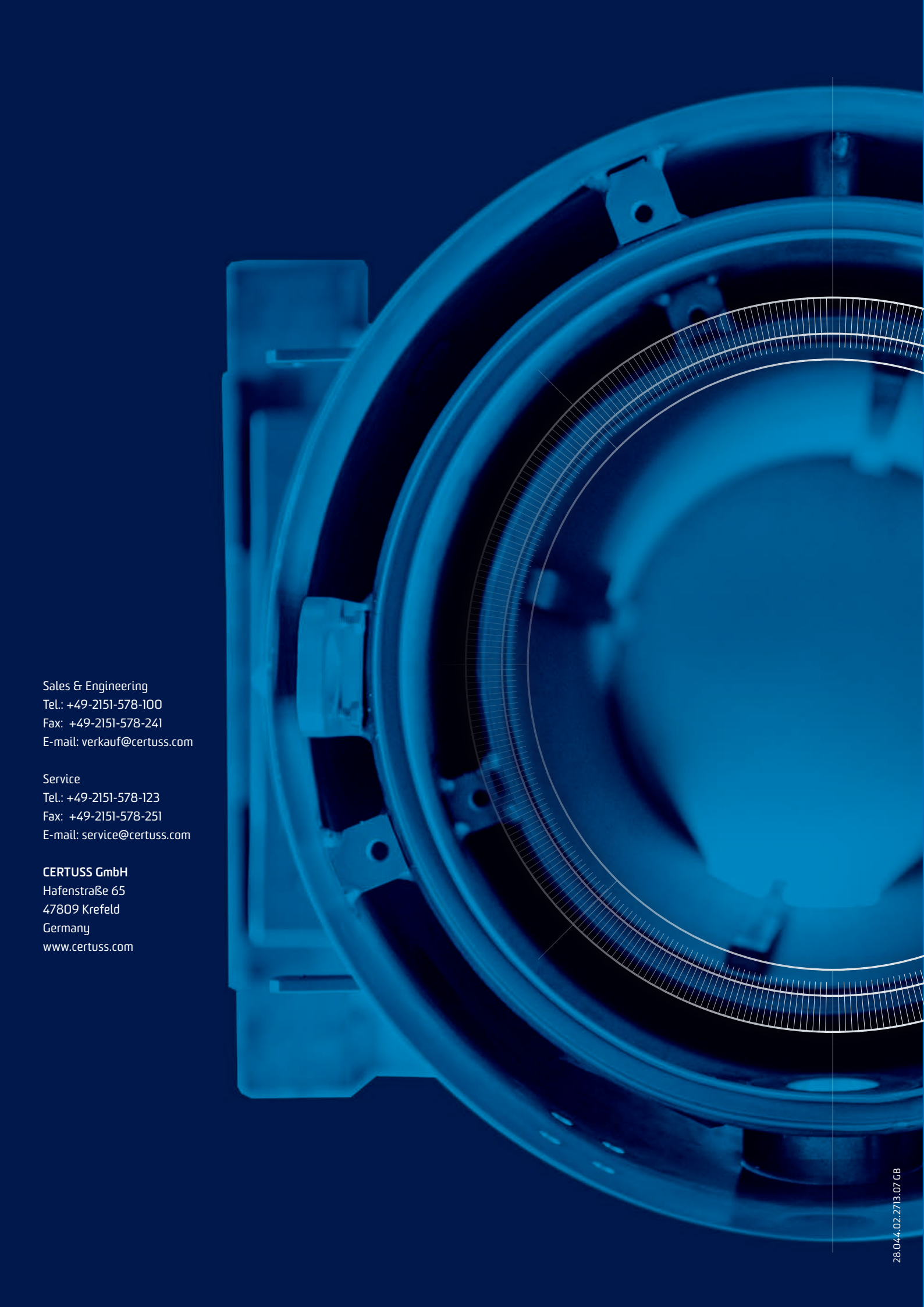

Sales & Engineering
Tel.: +49-2151-578-100
Fax: +49-2151-578-241
E-mail: verkauf@certuss.com

Service
Tel.: +49-2151-578-123
Fax: +49-2151-578-251
E-mail: service@certuss.com

CERTUSS GmbH
Hafenstraße 65
47809 Krefeld
Germany
www.certuss.com